



# FLAMEJET Powder Flame Spraying Torch



# FLAMEJET FLAME SPRAYING TORCH INTRODUCTION

A flame spraying torch for thermal spraying with powder using oxy-fuel gas flame. Function and safety are guaranteed through a gas mixture system using the injector principle.

Following fuel gases can be used: acetylene, propane, hydrogen in combination with oxygen as well as compressed air used for cooling purposes. The Flamejet is designed for universal application where wear and corrosive protection have to be considered.

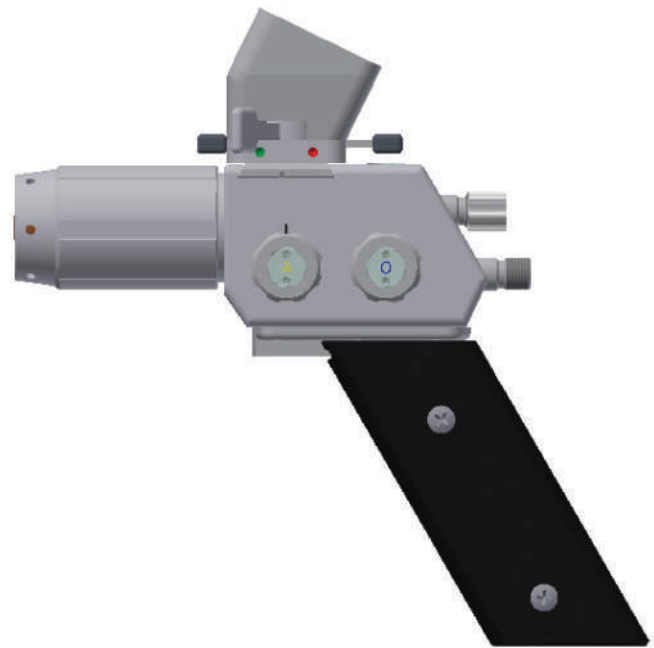

## KEY FEATURES

- Integrated powder transport system
- With the integrated gate valve, many types of transport gases can be used
- Overhead position through removable and 180° changeable powder connection
- Just one powder connector with adjustable slider for different capacities

## SPARE / MODIFICATION PARTS FLAMEJET

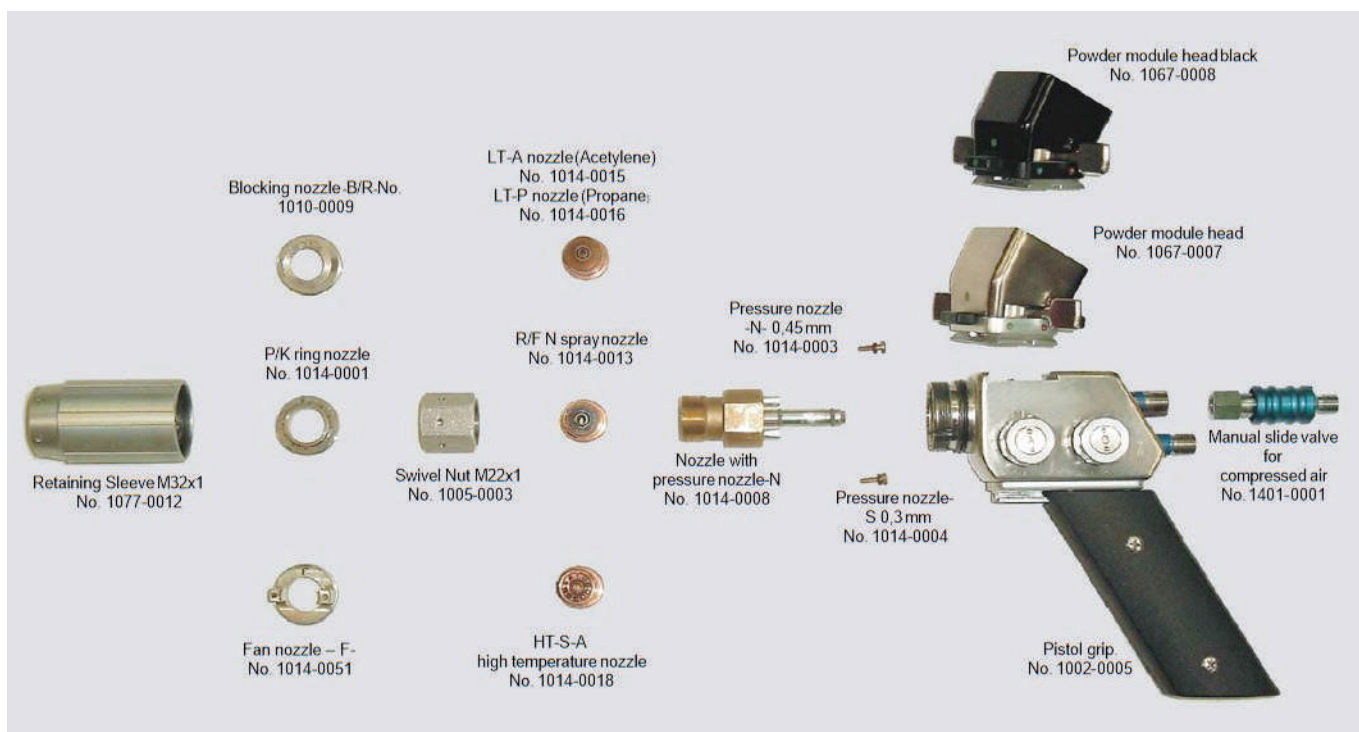

## AREAS OF USE / APPLICATION:

### Metal powder coating

For the hot and cold spraying techniques with self-fluxing or metal and ceramic powders

### Corrosion resistant coatings

On the basis of low melting metal flame spraying powder (for example zinc and aluminium)

### Plastic coatings

Many different types of thermo-plastics and epoxy material

**Because of its modular-building-system, the standard torch Flamejet can be used for many applications like glass mould plungers, steel rollers and piston rods 2 step Spray & Fuse process.**

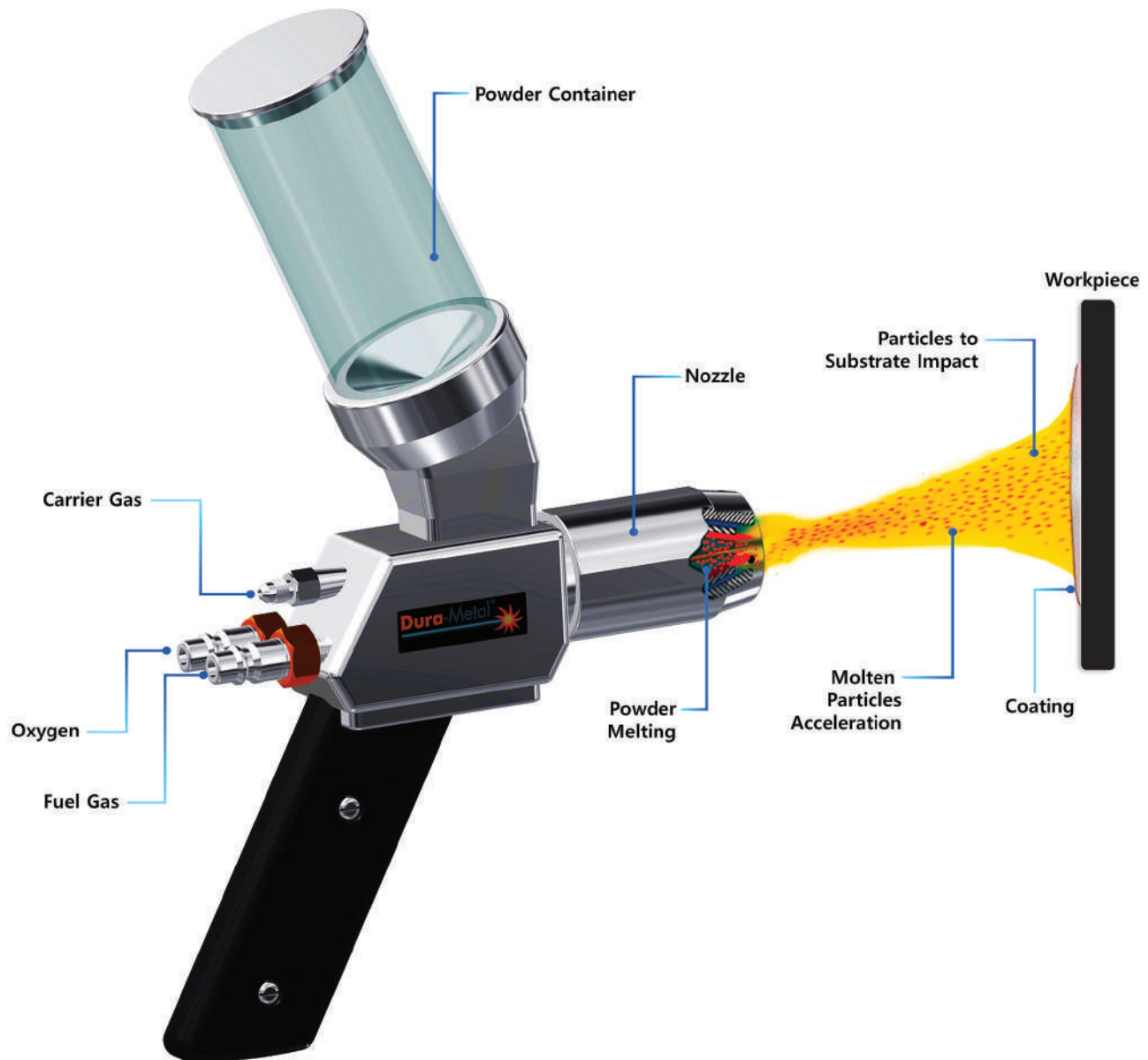

# ACCESSORIES & SPARE PARTS AVAILABLE ON REQUEST

Part Number	Description
5000-0014	FlameJet in an aluminium case with accessories
5000-0001	FlameJet G1/8RH – G1/8LH
1014-0013	R/F N-A spray nozzle (built in)
1014-0001	P/K ring nozzle (built in)
1383-0005	MSJ-Lathe carrier support attachment
1383-0004	Heat shield with clip-on shoe
7730-0007	Nozzle cleaning needle set
7730-0002	Adjustable wrench
7730-0001	Open ended fork wrench 24 mm
7730-0005	Brass wire brush
7730-0006	Gas lighter
7730-0008	Protective welding goggles
7730-0004	Tool bag
7730-0003	Allen key 4 mm
1014-0003	Pressure nozzle – N – 0,45 mm (built in)
7440-0394	O-ring 29,87 X 1,78
7440-0010	O-ring 5 x 1,5 FPM75
7440-0383	4 x O-ring 2,5 x 1,5
	<b>Modification parts for Zinc powder</b>
1010-0009	Blocking nozzle-B/R
1401-0001	Manual slide valve for compressed air
1014-0015	LT-A nozzle ( <b>Acetylene</b> ). Alternative: For example, zinc, plastic and other low temperature spray material
1014-0016	LT-P nozzle ( <b>Propane</b> ) for plastic, thermoplastic, etc.
	<b>Modification parts for plastic powder</b>
1067-0008	Blocking nozzle –B/R-
1401-0001	Manual slide valve for compressed air
1014-0015	LT-A nozzle ( <b>Acetylene</b> ). Alternative: For example, zinc, plastic and other low temperature spray material
1014-0016	LT-P nozzle ( <b>Propane</b> ) for plastic, thermoplastic, etc.
1067-0008	Powder module receptacle black

Part Number	Description
	<b>Modification parts for ceramic powder</b>
1014-0051	Fan nozzle F
1401-0001	Manual slide valve for ceramic air
1014-0004	Pressure nozzle S
1014-0018	HT/S-A high temperature nozzle
	<b>Accessories for FLAMEJET</b>
1383-0001	Refillable powder cartridge
1067-0007	Powder module head black
1014-0013	R/F N-A spray nozzle
1016-0002	Spray extension 500 mm 80° air-cooled
0181-0182	Hose Package A-O/2 5m G3/8LH-G1/4RH
7640-0617	Compressed air hose Mpa-4x3,5 G3/8RH-G1/8RH 6,5m
0069-4026	D1 Coupling pin -F G1/8LH -red
0069-4027	D1 Coupling pin -O G1/8RH -blue
3000-0074	Coupling DKG G3/8LH Fuel gas EN561
3000-0068	Coupling DKG G1/4RH Oxygen EN561
3000-0064	Flashback arrestor DGN G3/8LH EN730
3000-0065	Flashback arrestor DGN G1/4RH EN730
6454-0068	Cylinder regulator Acetylene 1,5bar ISO2503
6454-0065	Cylinder regulator Oxygen 200 / 10 bar
0005-0500	Swivel nut EN560 G1/8LH SW12 B7,2
0005-0501	Swivel nut EN560 G1/8RH SW12 B7,2
0006-0549	Hose pin EN560 G1/8X4mm
1383-0001	Refillable powder cartridge

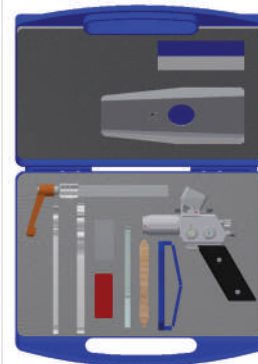

For application specific guidance on proper spraying procedures and parameters, please contact us at [tech.support@durametal-alloy.com](mailto:tech.support@durametal-alloy.com)

Dura-Metal North America Corporation ■ Dura-Metal (S) Pte Ltd ■ Dura-Metal (Shanghai) Co Ltd ■ Dura-Metal (Australia) Pty Ltd ■ PT Dura Metal Indonesia

Visit us @ [www.durametal-alloy.com](http://www.durametal-alloy.com)